

Low Resource Bronchoscope

Emily Dong, Barrett Fix, Conner Vastola, Ganesh Aruna, Kevin Derby, Yuelin Deng

VANDERBILT  UNIVERSITY
MEDICAL CENTER

VANDERBILT  School of Engineering

Project Importance

Within the last two decades there has been a rapidly increasing demand for healthcare services in low-income countries.

1. Geopolitical reasons: natural and manmade disasters
2. Burden of illness exceeding existing healthcare capacity
3. Lack of healthcare infrastructure
 - a. Scarcity of medical facilities, shortage of medication and medical equipment

Respiratory diseases are leading causes of death in low resource areas

The burden of Tuberculosis (TB) is the highest in low-resource areas and was one of the top 10 leading killers in 2018

Estimated 10.6M new cases and 1.5M deaths

Treatment success rate is 85% in 2018

Estimated TB incidence rates, 2017

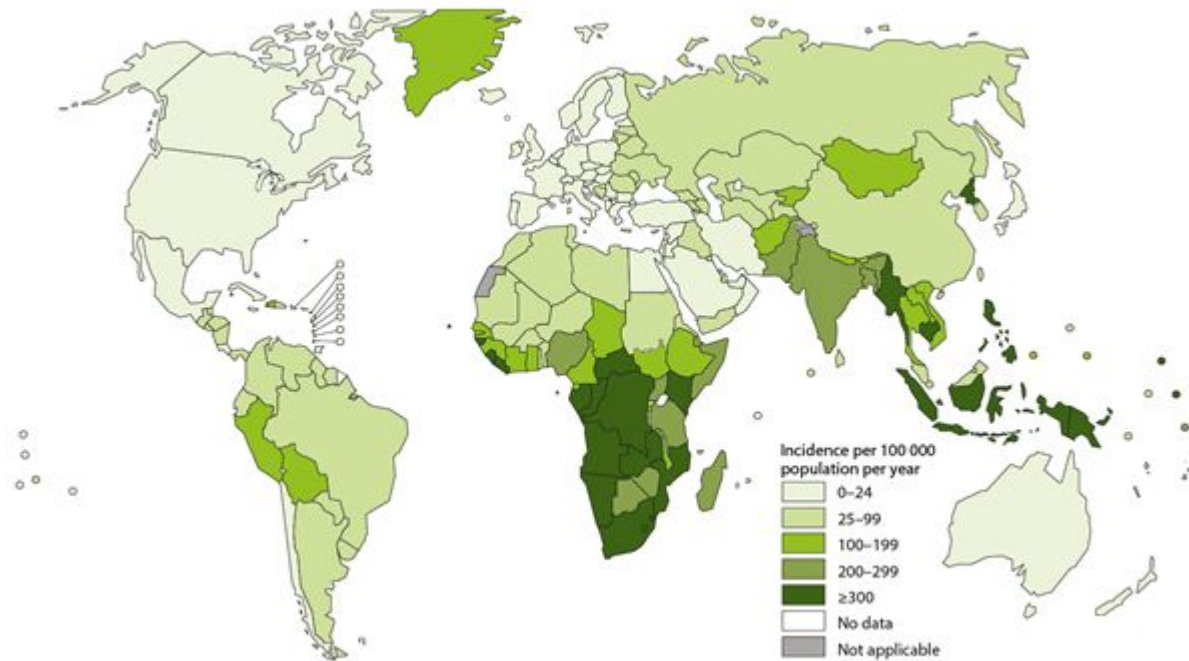

Bronchoscope collects a purer sample and better identifies origin of bacteria

- More than one third pulmonary TB patients cannot produce sputum
- Even when produced, there is an inadequate volume or quality in up to 20% of the case

Bronchoscope collects a purer sample and better identifies origin of bacteria

- More than one third pulmonary TB patients cannot produce sputum
- Even when produced, there is an inadequate volume or quality in up to 20% of the case
- Bronchoscope allows sputum to be collected at the suspected TB source

Bronchoscope collects a purer sample and better identifies origin of bacteria

- More than one third pulmonary TB patients cannot produce sputum
- Even when produced, there is an inadequate volume or quality in up to 20% of the case
- Bronchoscope allows sputum to be collected at the suspected TB source

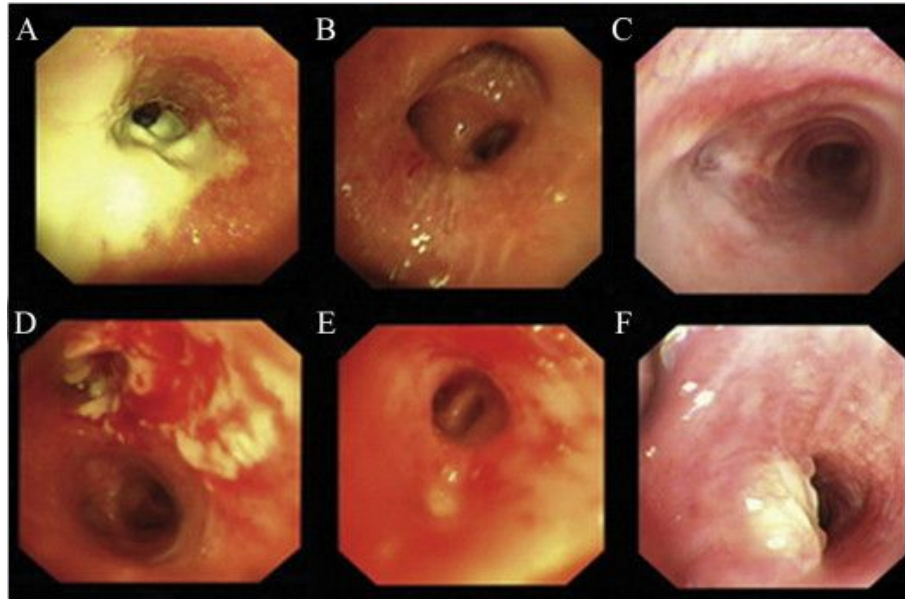

Bronchoscope collects a purer sample and better identifies origin of bacteria

- More than one third pulmonary TB patients cannot produce sputum
- Even when produced, there is an inadequate volume or quality in up to 20% of the case
- Bronchoscope allows sputum to be collected at the suspected TB source
 - Allows doctors to explore airways and collect adequate volume/quality
 - 2015 Review: 83% - 92% sensitivity and 91% - 98% specificity

Current Market

- Two major players in the reusable bronchoscope field
 - Olympus - high baseline cost: 7,000-15,000 USD
 - Pentax - lower base cost: 4,000 USD

Additional Cost Factors

Cleaning costs between 100 and 300 USD

Reusable vs Single Use probes

- Single use probes are easier to use
- Reusable probes have lower cost per procedure

Key Differences

Our Device

1. Decreased Video Quality

800x800 pixel resolution at 60 fps

Capable of edge detection



Current Devices

1. HD Video Quality

26-inch full HD LCD Panel

Built in software for blood vessel visualization



Key Differences

Our Device

1. Decreased Video Quality

800x800 pixel resolution at 60 fps

Capable of edge detection



Essential Specifications

Monitor standards have not been established in digital pathology

- Current monitors on the market range from 640x480 pixels to 6400x4800 pixels
- The lower end resolution allows us to save cost while remaining in market range

Key Differences

Our Device

1. Decreased Video Quality
2. Lower Material Quality

ABS or PLA (plastic) body

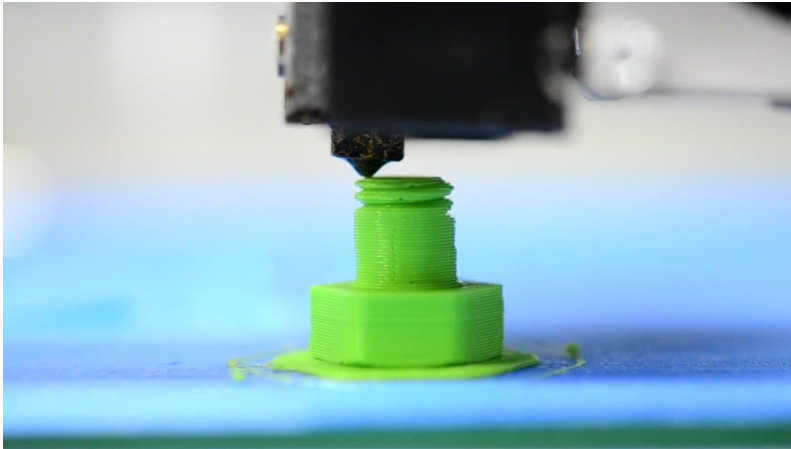

Current Devices

1. HD Video Quality
2. Higher Material Quality

Proprietary body material with polymer coating (polycarbonates, polypropylene, polyethylene)

- Versatile plastics with low moisture absorption
- Heat resistance
- Chemical and bacteria resistant

Key Differences

Our Device

1. Decreased Video Quality
2. Lower Material Quality
3. Reduced Functionality

Max angulation: 90°/90° (up/down)
90°/90° (left/right)

Available Functions: suction and camera

Current Devices

1. HD Video Quality
2. Higher Material Quality
3. More Functionality

Maximum angulation: 210°/130° (up/down)
120°/120° (left/right)

Available Functions: biopsy/suction, air channel,
water channel, fiber optic image bundle

Problem Statement

We aim to design and develop a bronchoscope that is more cost efficient, portable, and durable than current devices on the market and can also be controlled with common appliances such as iPhone and iPad technology for universal ease of use and increased availability.

Needs Assessment

Functionality

- Match competitor specifications as closely as possible
- Equipped with a companion application with integrated IP modules

Cost Reduction

- Materials and hardware shall be selected to reduce cost without large sacrifices to performance
- The main probe shall be reusable with a single use outer sheath to eliminate reprocessing fees

Ease of Use

- Intuitive control system that non-professionals can learn to operate
- Integrated IP modules shall aid non-professionals in point-of-care diagnostics
- Parts will be easily replaceable in case of failure

Portable

- Powered using single cell batteries
- Coiled to save space during transport

Durable

- Electronics and optics shall be properly insulated within the main probe
- Parts shall be optimized for durability for lower replacement costs

Camera Functionality

Logitech C922

- Used for the purpose of prototyping, since small camera has not arrived yet.
- USB camera connects directly to the Raspberry Pi
- Allows real-time video that can be processed.



Camera Functionality

VNC Server / Secure Shell (SSH)

- Accessing a remote server (microcontroller) with a mobile device (client) requires SSH.
- Once the connection is established, the mobile device can run programs and scripts.
- So far, we have edge detection and isolation working.

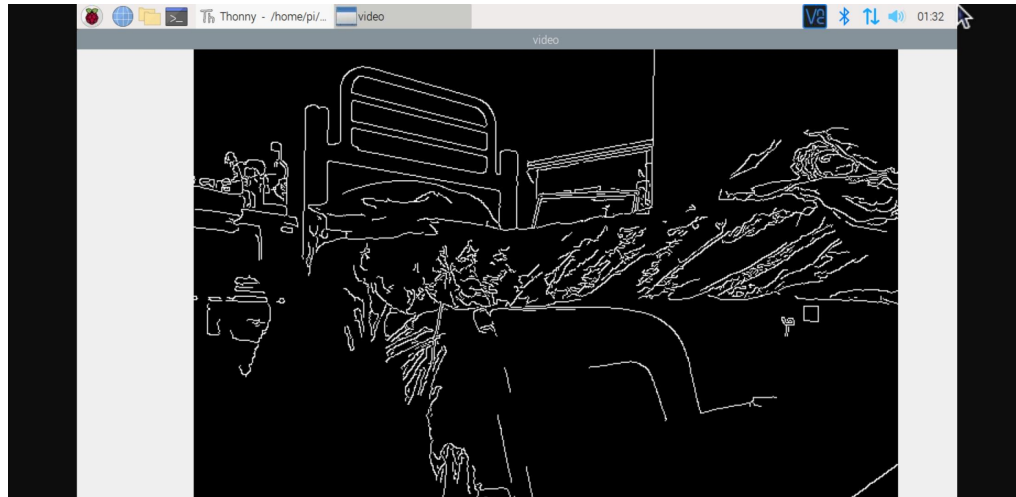

Mechanical Design #1

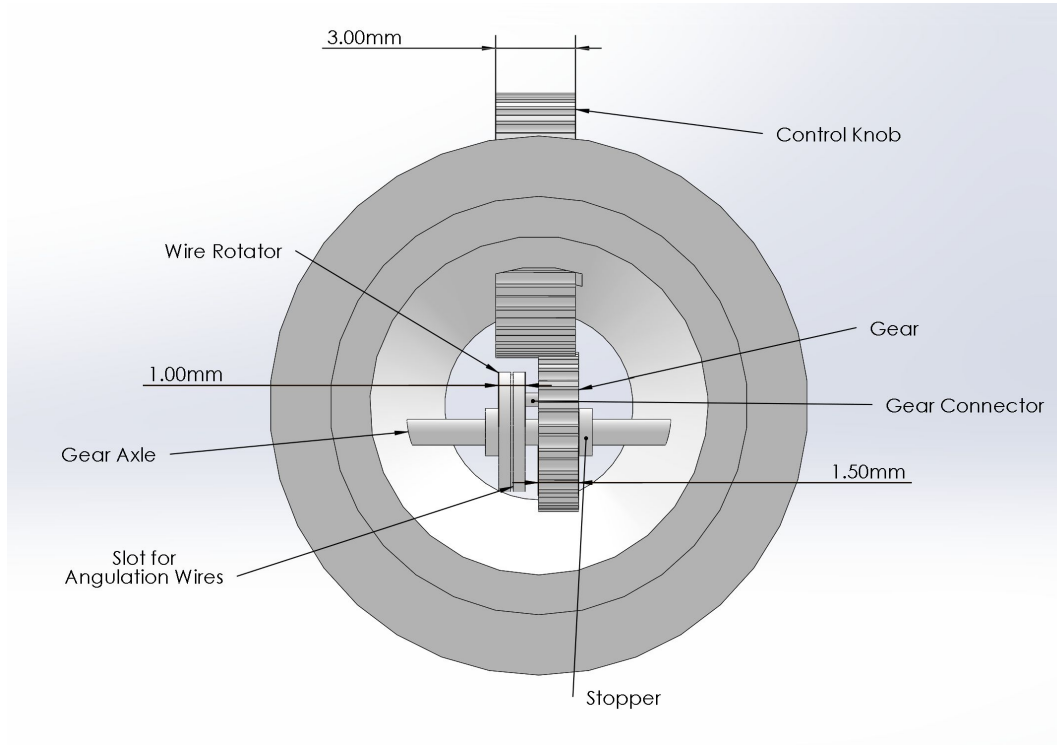

Recent Developments

- Split main body and rotational end piece in half
 - Allows for knob and gears to be placed on corresponding axles
 - Would allow for easy repair in low resource environments
 - Ultimately allows for rotation of end piece
- Added holes and pegs for attachment of split pieces
- Extruded borders of pieces for secure fit
- Scaled up parts (x2.5) to be printed
 - Wondry printers have low resolution and not big enough to print scaled main body

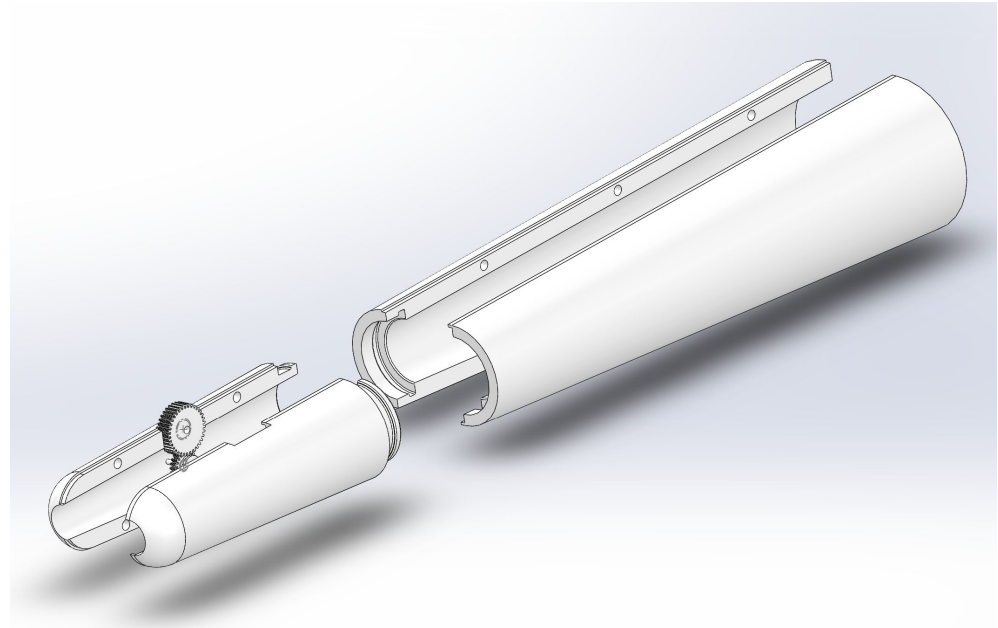

Main Body Split

Side A

- Cut extrusions on border
- Holes for attachment
 - Slightly bigger than pegs
- Extrusion to fit rotational end piece

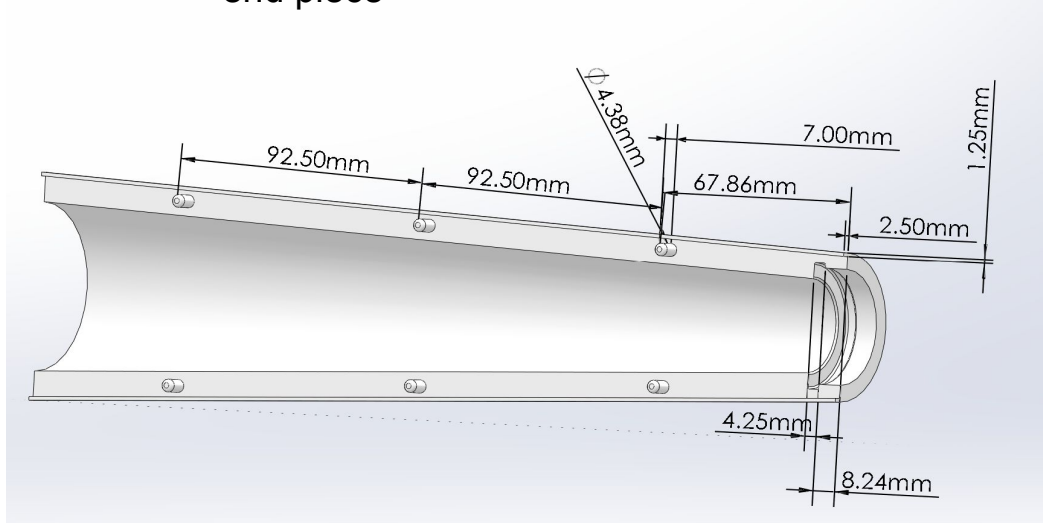
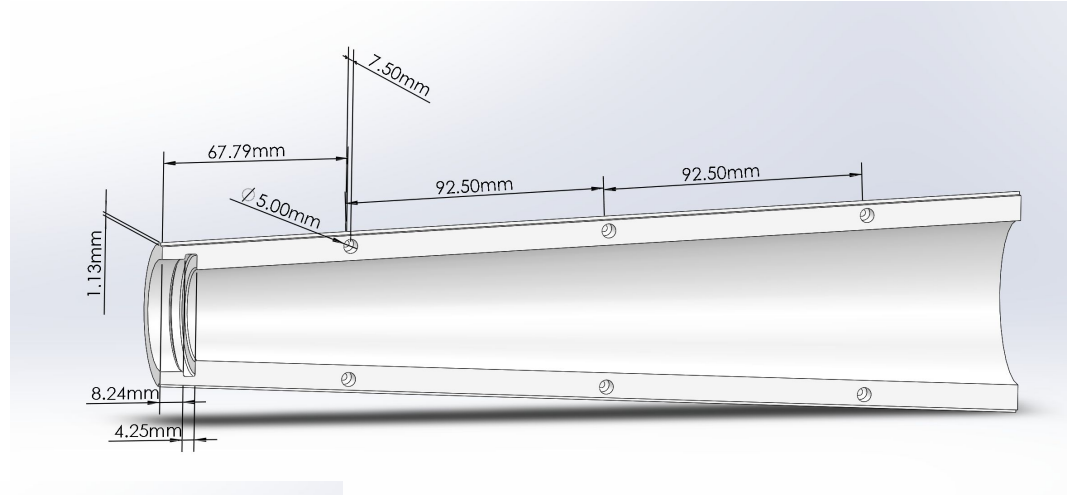

Side B

- Boss extrusions on border
- Pegs for attachment
 - Slightly smaller than holes
- Extrusion to fit rotational end piece

Rotational End Piece Split

Side A

- Cut extrusions on border
- Holes for attachment
 - Slightly bigger than pegs
- Extrusion to fit into main body
 - Slightly smaller than main body extrusion to allow rotation

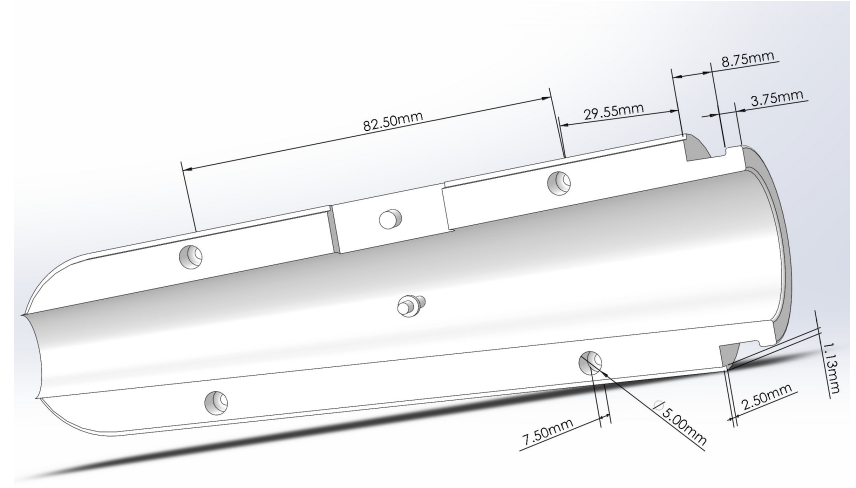
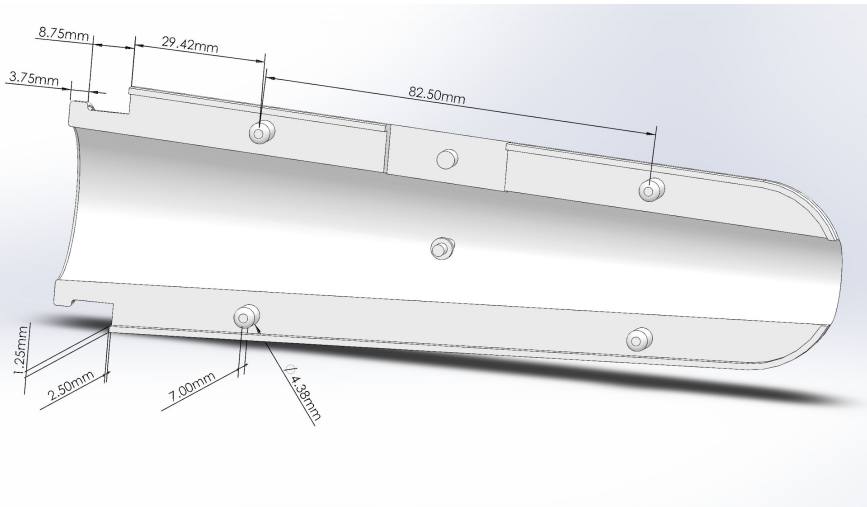

Side B

- Boss extrusions on border
- Pegs for attachment
 - Slightly smaller than pegs
- Extrusion to fit into main body
 - Slightly smaller than main body extrusion to allow rotation

Issues with Mechanism #1 Development

- Initial print revealed that Wondry's 3D printers don't have high enough resolution for pegs, holes, and gears
- After scaling, it was discovered that the 3D printers are not big enough to print main body pieces
- Scaled print of rotational end piece and gears was never started by Wondry mentors although print was set up last Friday
 - Delayed usable print

Mechanical Design #2

- LEGO large scale prototype
 - Allows for 2 axis control of bending arm
 - Scrapped
- Too large and bulky
- Mechanism worked poorly

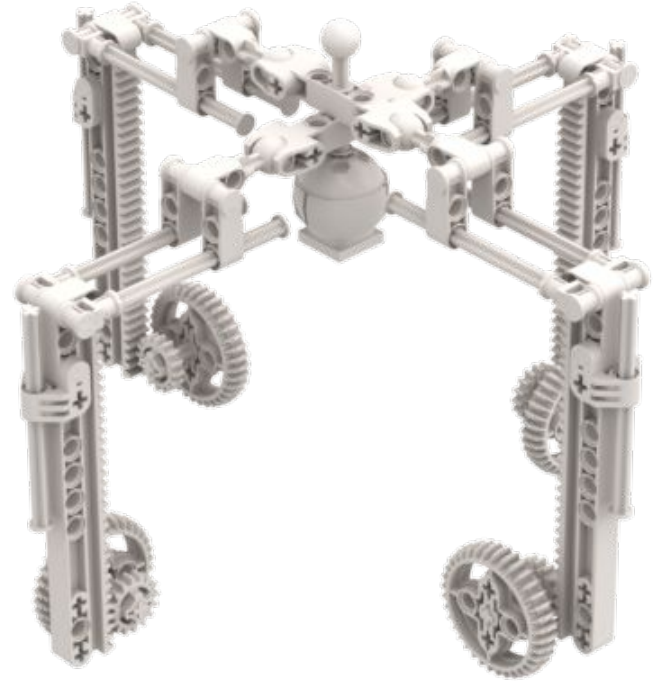

New Mechanical Design #2

- Similar joystick control concept
 - Design based off of N64 controller joystick
 - Modified open access SolidWorks model taken from GrabCAD
 - 3D printed in the Wondry
- Design concept
 - Joystick in “bowl” operating 2 arms controlling gears for both axes
 - Allows for 2 axis control with one joystick

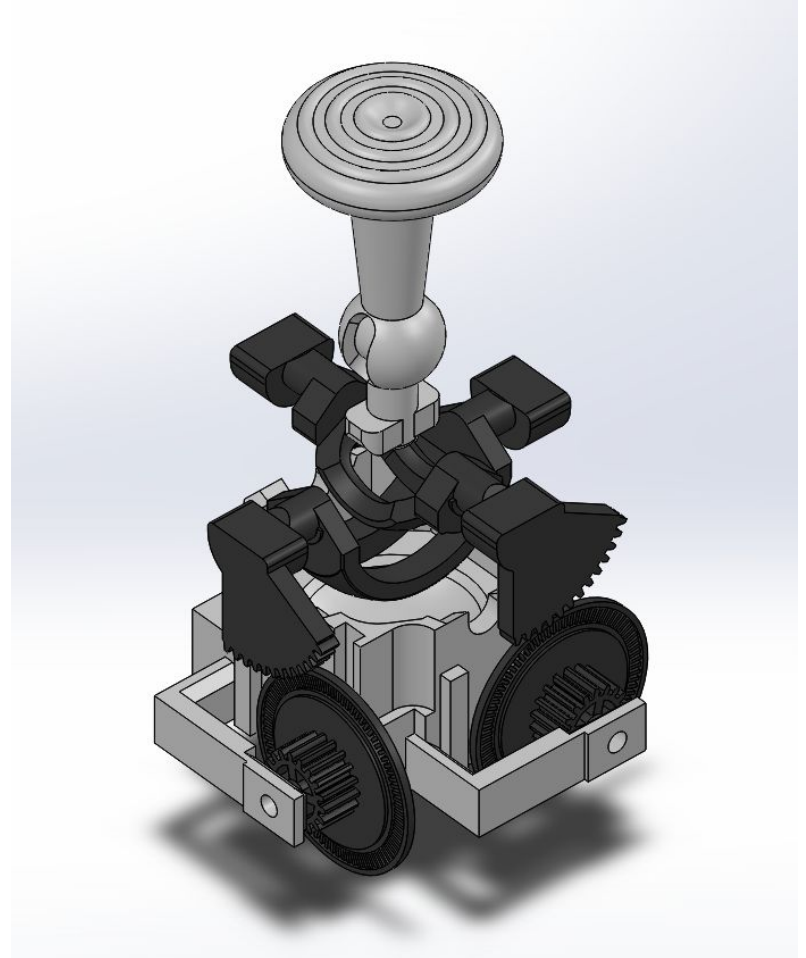

New Mechanical Design #2

- Modifications to N64 joystick
 - First layer “encoder wheel” changed to a step-up gear
 - Second layer added with a second step-up gear which attaches to angulation wires
 - Double step-up system ensures amplification of input movements
- Insertion tube attachment
 - Simple structure for insertion tube to attach to and holes for angulation wires to thread through
 - Ensures angulation wires don't get tangled
- Still contains several flaws

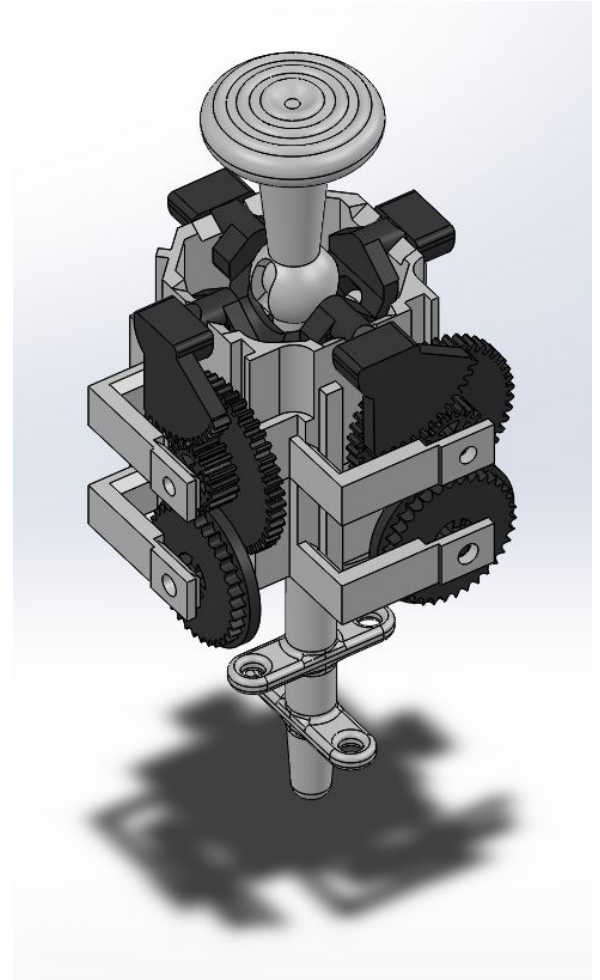

Camera Implementation

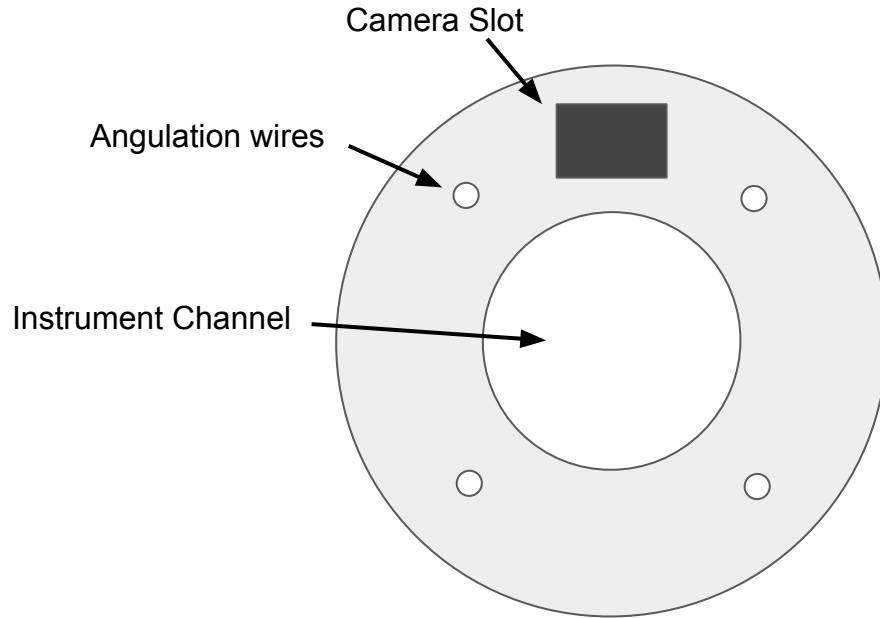

- Modified insertion tube disk
 - Final disk modified to fit camera
 - Electrical wiring will run parallel to angulation wires through the insertion tube
 - Ensures electrical wires do not tangle with angulation wires

Camera Status

- Lack of communication between us and Vanderbilt BME Office
- Original Assumption was that camera was ordered January 29th
- We were told February 12th that the order required quote from Arrow.
- We called Omnivision after receiving the email and found a quote
- After we called the vendors to get a quote, the BME office got back to us and said they had received a quote
- Received an email from the BME office yesterday saying that part would taking 4-6 weeks and to find vendor.

Gantt Chart



Sources

Adhikari, N., Fowler, R., Bhagwanjee, S., & Rubenfeld, G. (2010). Critical care and the global burden of critical illness in adults. *The Lancet*, 376(9749), 1339-1346. doi:10.1016/s0140-6736(10)60446-1

Goussard, P., Gie, R., Kling, S., Andronikou, S., Lucas, S., Janson, J., & Roussouw, G. (2012). Bronchoscopic assessment of airway involvement in children presenting with clinically significant airway obstruction due to tuberculosis. *Pediatric Pulmonology*, 48(10), 1000-1007. doi:10.1002/ppul.22747

Haniffa, R., De Silva, A., Iddagoda, S., Batawalage, H., De Silva, S., & Mahipala, P. et al. (2014). A cross-sectional survey of critical care services in Sri Lanka: A lower middle-income country. *Journal Of Critical Care*, 29(5), 764-768. doi:10.1016/j.jcrc.2014.04.021

P. Goussard & R.P. Gie (2016) The need for bronchoscopic services for children in low and middle-income countries, *Expert Review of Respiratory Medicine*, 10:5, 477-479, DOI: 10.1586/17476348.2016.1162716

(2020). *Olympus-europa.com*. Retrieved 29 January 2020, from https://www.olympus-europa.com/medical/rmt/media/en/Content/Content-MSD/Documents/Brochures/BF-P190_EVIS_EXERA_III_EN_E0428821_20140225_L7.pdf